



Modular ice maker - Granular system
Daily production up to 300 kg

Hotel	████████████████████
Restaurant	████████████████████
Fast food	████████████████████
Bar	████████████████████
Disco	████████████████████
Fish market	████████████████████
Supermarket	████████████████████
Medical & SPA	████████████████████
Industry	████████████████████

► Position n°



► **Features & Plus**

- Granular ice - 80-82% dry
- 1l (water) - 1kg (ice) - only Air cooled
- AISI 304 SS Scotch Brite finish
- Tropical class +43°C
- Specific volume 1 m³ = 550 kg of ice
- Removable and cleanable air filter
- AISI 304 SS evaporator
- Air or water cooling system
- Easy cleanable internal rounded surfaces
- Dust-proof water basin
- RoHS Free
- Electromechanical operation
- ON-OFF rocker switch
- Rotation sensor on low speed shaft
- Automatic water charge
- Standard and special voltages
- Frame in INOX
- HFC Free



Removable and cleanable air filter



AISI 304 SS evaporator



Dust-proof water basin



Easy cleanable internal rounded surfaces



Frame in INOX

► **Usable Bins**

- Bin 240PE
- Bin 110
- Bin 200
- Bin 350
- Roller Bin 100
- Double Roller Bin 100

► **Prod. 24h**

Air temp.	Air temp.		Water temp.		Kg	Lbs
	10° C	50° F	7° C	45° F		
	21° C	70° F	15° C	60° F		
					300	661
					280	617

2 Years Warranty
subject to limitations

► **Certifications available for this model**



We are Brema





Ice Flakes

FHTM 280 A/W HC



Modular ice maker - Granular system Daily production up to 300 kg

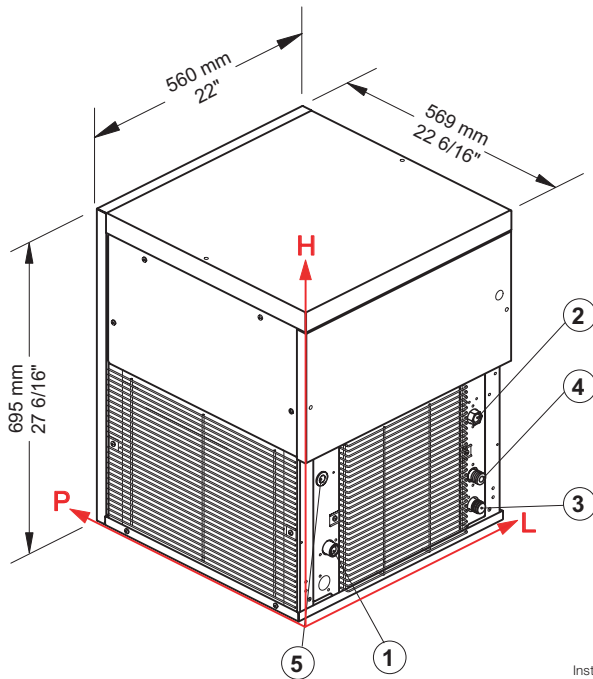

Installation



▶ Working conditions

- Location: **Indoor**

	Min	Max
Ambient temperature	+10° C / +50° F	+43° C / 110° F
Water temperature	+3° C / +37° F	+32° C / +90° F
Voltage	-10%	+10%
Water inlet pressure	1bar (14 psi)	6bar (84 psi)

▶ Performances

Air temperature	7° C	45° F	15° C	60° F	21° C	70° F	Ice production (kg)
10° C	300 kg						
50° F		661 lbs					
21° C			280 kg				
70° F				617 lbs			
32° C					230 kg		
90° F						507 lbs	

▶ Connections

All measures are referred to the down-left corner (L-H-Ø)

- ① Water in.: 85,5 mm / 3 6/16" - 130 mm / 5 2/16" - 3/4"
- ② Cond. water in.: 479,5 mm / 18 14/16" - 260 mm / 10 4/16" - 3/4"
- ③ Water out.: 479,5 mm / 18 14/16" - 65 mm / 2 9/16" - 24 mm / 15/16"
- ④ Cond. water out.: 479,5 mm / 18 14/16" - 130 mm / 5 2/16" - 24 mm / 15/16"
- ⑤ Electrical connections: 67,5 mm / 2 11/16" - 290 mm / 11 7/16"
- ② ④ Only for water cooling systems

▶ Technical information

Production in 24h	280 kg / 617 lbs	Water consumption	A: 1 l/kg - 12,0 gal/100 lbs
Cooling system	A - W		W: 6 l/kg - 72 gal/100 lbs
Refrigerant	R290	Sizes (L-P-H mm)	560 - 569 - 695
Standard voltage	220-240 V ~ 50 Hz	(L-P-H in)	22 - 22 6/16 - 27 6/16
Average power consumption	1100 W	Sizes with pack (L-P-H mm)	645 - 645 - 910
Fuse	10 A	(L-P-H in)	25 6/16 - 25 6/16 - 35 13/16
Electrical consumption	11 kWh/100kg	Net weight	83 kg / 183 lbs
Finish	AISI 304 stainless steel, scotch brite	Gross weight	93 kg / 205 lbs

All the technical information need to be considered at the following conditions:

- Ambient temperature +21° C
- Water temperature +15° C
- Electrical consumption at +32° C (standard voltage)
- Average power consumption at +43° C (standard voltage)

Models and specifications are subject to change without notice

Rev. 04 - Issued September 2019

Bim + Data
download

